













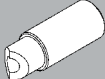



< Table of combinations of replacement parts >

| Blind Rivet Dia. | AR - 011MX  | AR - 011HX   |   |  |   |
|------------------|---|--|---|--|---|
|                  | Nosepiece   | Nosepiece (Hole dia.)  | Ultra Jaws  | Jaw Case Head  | Jaw Pusher  |
| 2.4mm (3/32")    | 2.4  | 2.4 (1.8 mm)  | "M"  | "M"   | "M"  |
| 3.2mm (1/8")     | 3.2  | 3.2 (2.3 mm)  |   |  |   |
| 4.0mm (5/32")    | 4.0  | 4.0 (2.9 mm)  |   |  |   |
| 4.8mm (3/16")    | 4.8  | 4.8 (3.3 mm)  | "H"  | "H"  | "H"  |
| 6.4mm (1/4")     |      | 6.4 (4.3 mm)  |   |  |   |

 Shaded areas indicate parts which are installed in the tool as standard accessories.

**5** Please change either straight joint or rotary joint by using spanner or similar tools which are suitable for your working environment.

< Table of combinations of replacement parts >

| Type of joint  | Fitting to A  | Fitting to B      |
|----------------|---------------|-------------------|
| Straight joint | Nipple Unit   | Change Plug Unit  |
| Rotary joint   | End Plug Unit | Rotary Joint Unit |

 Shaded areas indicate parts which are installed in the tool as standard accessories.

Screw size of the air intake of straight joint or rotary joint is parallel pipe thread G1/4.

Parts of straight joint are option. (Refer to page 13.)

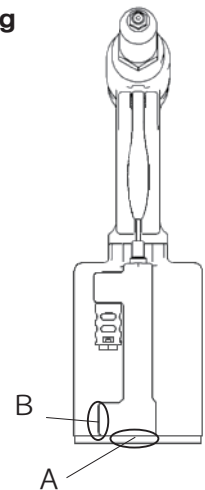

# ●PARTS TABLE OF AR-011 MX

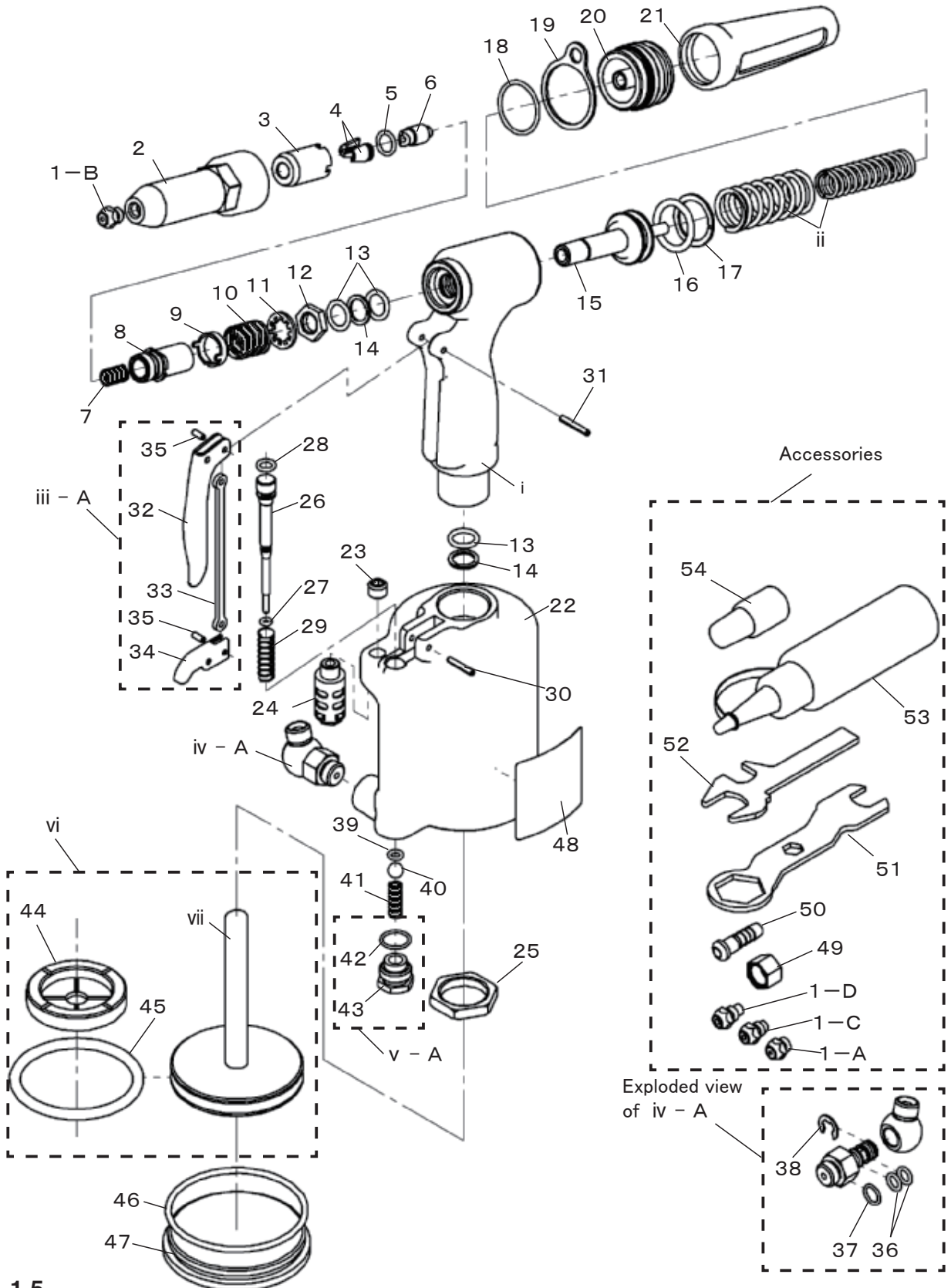

| Index No. | Part Name             | Code No. | Material | Index No. | Part Name                   | Code No. | Material |
|-----------|-----------------------|----------|----------|-----------|-----------------------------|----------|----------|
| ①-A       | Nosepiece 2.4 (3/32)  | 10027    | Steel    | 30        | Spring Pin 3 × 18           | 10145    | Steel    |
| ①-B       | Nosepiece 3.2 (1/8)   | 10028    | Steel    | 31        | Spring Pin 3 × 20           | 10251    | Steel    |
| ①-C       | Nosepiece 4.0 (5/32)  | 10029    | Steel    | iii - A   | Trigger (Long) Unit "M"     | 20510    | Steel    |
| ①-D       | Nosepiece 4.8 (3/16)  | 10030    | Steel    | 32        | Trigger (Long)              | 13121    | Steel    |
| 2         | Frame Head            | 10105    | Steel    | 33        | Trigger Connector Rod       | 10120    | Steel    |
| ③         | Jaw Case Head         | 10280    | Steel    | 34        | Trigger Lever               | 10119    | Steel    |
| ④         | Ultra Jaws (pair) 'M' | 10281    | Steel    | 35        | Spring Pin 3 × 7.2          | 23595    | Steel    |
| ⑤         | O-ring P-10           | 10274    | Rubber   | iv - A    | Rotary Joint Unit           | 42502    | ②        |
| ⑥         | Jaw Pusher            | 10132    | Steel    | ③⑥        | O-ring P-7                  | 10149    | Rubber   |
| ⑦         | Jaw Pusher Spring     | 10133    | Steel    | 37        | O-ring S-10                 | 10151    | Rubber   |
| ⑧         | Jaw Case              | 10279    | Steel    | 38        | Retaining ring E-7          | 10285    | Steel    |
| 9         | Jaw Case Collar       | 10286    | Steel    | ③⑨        | Valve Packing               | 66064    | Rubber   |
| 10        | Collar Spring         | 10287    | Steel    | 40        | Valve (Steel Ball 8.0)      | 10247    | Steel    |
| ⑪         | Lock Washer           | 10148    | Steel    | 41        | Valve Spring                | 10444    | Steel    |
| 12        | Jaw Case Lock Nut     | 10113    | Steel    | v - A     | End Plug Unit               | 65180    | ③        |
| i         | Frame Unit            | 65193    | ①        | 42        | O-ring S-14                 | 10152    | Rubber   |
| ⑬         | O-ring P-12           | 10128    | Rubber   | 43        | End Plug                    | 65178    | Brass    |
| ⑭         | B-ring P-12           | 10129    | Plastic  | vi        | Air Piston Unit             | 65198    | ②        |
| 15        | Oil Piston            | 10241    | Steel    | ⑦⑩        | Air Piston Rod Unit         | 65199    | ④        |
| ⑯         | O-ring P-22A          | 10130    | Rubber   | ④④        | Bumper (Rubber Cushion)     | 29736    | Rubber   |
| ⑰         | B-ring P-22A          | 10131    | Plastic  | ④⑤        | O-ring P-60                 | 10134    | Rubber   |
| ii        | Retun Spring          | 66004    | Steel    | ④⑥        | O-ring G-70                 | 10080    | Rubber   |
| 18        | O-ring S-26           | 10153    | Rubber   | 47        | Cylinder Cap                | 10011    | Aluminum |
| ⑱         | Hanger Clip           | 10106    | Steel    | 48        | Warning Label               | 61075    | ⑤        |
| 20        | Frame Cap A           | 66002    | Aluminum | 49        | Air Hose Joint Nut 1/4      | 10139    | Brass    |
| ⑳         | Safety Cap            | 42505    | Rubber   | 50        | Air Hose Joint 1/4          | 10140    | Brass    |
| 22        | Air Cylinder          | 65197    | ④        | 51        | Spanner 'A'                 | 10141    | Steel    |
| 23        | Plug                  | 14359    | Steel    | 52        | Spanner 'B'                 | 10142    | Steel    |
| ㉒         | Silencer              | 14355    | Plastic  | ⑤③        | Hydraulic Oil (in a bottle) | 10012    | Plastic  |
| 25        | Frame Lock Nut        | 10112    | Steel    | ⑤④        | Lubricant Oil (in a bottle) | 64088    | Plastic  |
| 26        | Valve Pusher          | 65187    | Steel    | Option    |                             |          |          |
| ㉔         | O-ring P-3            | 10333    | Rubber   | iii - B   | Trigger (Short) Unit 'M'    | 10021    | Steel    |
| ㉕         | O-ring P-7            | 10149    | Rubber   | iv - B    | Change Plug Unit            | 42509    | ⑥        |
| 29        | Valve Pusher Spring   | 12132    | Steel    | v - B     | Nipple Unit                 | 65191    | ③        |

※ Parts with circled Index No. are consumable parts. They should be replaced periodically.

※ Index No. i (Frame Unit) includes Index No.13 and 14 (O-ring P-12 and B-ring P-12).

※ Index No.22 (Air Cylinder) includes Index No.23 (Plug).

※ Unit parts materials

- ① Aluminum, Rubber, Plastic      ② Aluminum, Rubber, Steel      ③ Brass, Rubber  
 ④ Aluminum, Steel                      ⑤ Paper, Plastic                      ⑥ Rubber, Plastic